



# ASLD 2200

## Analogue Output Automatic Sludge Blanket Level Monitor

PRODUCT DATASHEET

### APPLICATIONS

Final Settlement Tanks  
Primary Settlement Tanks  
WRc Thickeners  
Clarifiers

### FEATURES

Simple to Use  
Very Low Cost of Ownership  
Automatic Bridge Clearance Control  
Sensor Tracks the Sludge Interface  
Tolerant of Poorly Formed Blanket

### BENEFITS

Early Warning of Blanket Failure  
Automatic De-sludging  
Not Confused by Blanket Breakdown

### COMPATIBLE SENSORS

Soli-Tech 20v2 Sensor  
Infrared Sensor



The ASLD 2200 is a fully automatic sludge blanket level detector primarily designed for the water and waste water industry but could be applied to other types of process. It utilises a servo-driven sensor which continually tracks the settled interface and produces a 4-20 mA output which is proportional to the depth of the blanket.

The ASLD is supplied with either a Infrared or Soli-Tech 20v2 sensor. The use of infrared attenuation as the principle of operation for the sensor allows Partech to ensure sufficient sensitivity to monitor sludge blankets in a wide variety of applications. It should be noted that sensor selection can be site dependent, Partech are happy to provide full support in the selection of the correct sensor.

The sensor will normally be in the area of the tank just above the sludge and will therefore be kept away from the worst of the fouling that can occur in the treatment of either potable or dirty water.

Provision must be made for transmission of the output signal to the control system; this is normally possible via spare slip rings. Where this is not possible a radio telemetry option is available, allowing transmission directly to the control system without the need for installation of cables.

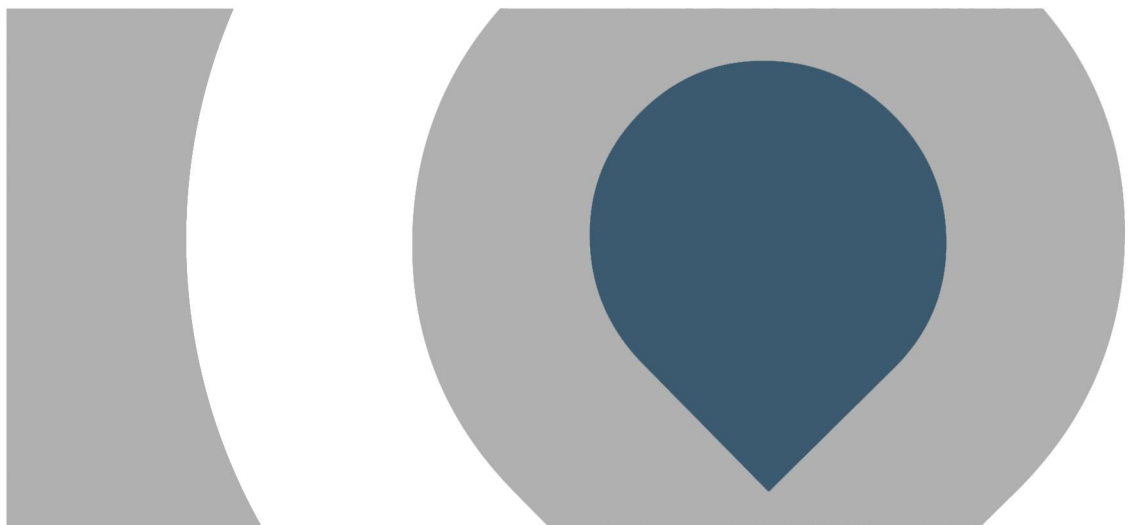

Call us on +44 (0) 1726 879800 [www.partech.co.uk](http://www.partech.co.uk)





# ASLD 2200

## Analogue Output Automatic Sludge Blanket Level Monitor

### PRODUCT DATASHEET

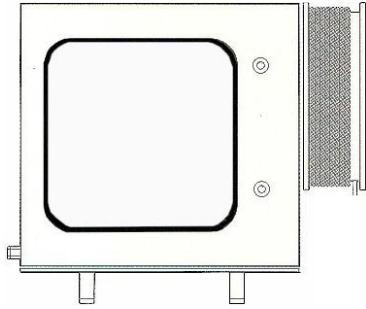

#### Physical

Dimensions	490 x 350 x 382 mm (HxWxD)
Weight	15 kg
Protection Class	IP55 Outer Enclosure with IP65 Electronics Housing
Enclosure Material	GRP Outer with Polycarbonate Inner
Cable Entries	3 x PG11 (cable 5 to 10 mm)
Cable Size	Max Conductor Cross Section 2.5 mm <sup>2</sup>

#### Environmental Data

Operating Temperature	0 to 50°C
Storage Temperature	-20 to 70°C
Location	Indoor or Outdoor

#### Electrical

Power Supply	115/230 VAC +10/-15% Field Selectable
Power Consumption	25VA

#### Outputs and User Interface

Analogue Output	4-20 mA, maximum load resistance 500 ohm
Relay Output	1, this alarms at 0 and 100% only and is not adjustable
Contacts	Contact Closure
Rating	0.5A @ 100VDC
Local Annunciation	6 LED's on Main CCA
Display	3 Digit, 7 Segment LED Display of 0-100%
Setup	Potentiometer and Push Buttons on main CCA

#### Measurement Details

Accuracy	Typically +/-5%
Resolution	+/- 100 mm
Response Time	5 second delay, tracks blanket at 1 metre per minute
Depth Range	0-1.5 to 0-20 metres
	Accuracy and resolution statements are dependent on the settling characteristics of the solids and can vary during operation of the plant.

#### Sensor Selection

Settlement Tank	IR100 Sensor – Special Applications Only ST20 0-1500 or IR40 – WTW Clarifier, STW Final Settlement ST20 0-10000 or IR15 Sensor – WTW Thickener, STW Primary Settlement ST20 0-30000 or IR8 Sensor – STW Thickener
-----------------	----------------------------------------------------------------------------------------------------------------------------------------------------------------------------------------------------------------------------

#### Mounting

Type	Requires bracket to mount on Handrail
Bracket/Plate	Part Number 101170 for attachment to handrail

Publication No: 184180DS-Iss08

The company reserves the right to alter the specification without prior notice. E&OE

Call us on +44 (0) 1726 879800 [www.partech.co.uk](http://www.partech.co.uk)

