

Model 405 nm NO₂/NO/NO_x Monitor™

Direct Measurement of NO₂ by Absorbance
EPA Federal Equivalent Method (FEM) for NO₂



The Model 405 nm NO_x Monitor ("nm" for "nanometer" and for "NO_x Monitor") is designed for the direct measurement of atmospheric nitrogen dioxide (NO₂), nitric oxide (NO) and total reactive oxides of nitrogen (NO_x = NO + NO₂) in the concentration range 0-10,000 ppb (0-10 ppm) for NO₂ and 0-2,000 ppb (0-2 ppm) for NO with high precision and accuracy. In this instrument NO₂ is measured directly by absorbance at 405 nm. NO is measured by selective conversion with ~100% efficiency using the highly selective reaction of NO with ozone (O₃). Total NO_x is obtained by addition of NO and NO₂.

Unlike chemiluminescence instruments where NO₂ must be converted to NO using either a molybdenum or photolytic converter with highly variable efficiency, in the Model 405 NO_x Monitor nitrogen dioxide is measured directly by absorbance, analogous to an ozone monitor. Because NO₂ has a much lower absorption cross section than ozone, a folded cell with corner mirrors is used to produce a long absorbance path of ~2 m to achieve approximately the same sensitivity for NO₂ as we do for ozone in our UV-absorbance-based ozone monitors. The wavelength of 405 nm was chosen because no other species found in ambient air has significant absorbance at that wavelength, making the Model 405 nm extremely selective for NO₂.

Although our Model 410 Nitric Oxide Monitor can measure NO and NO_x when used in combination with our Model 401 NO₂ Converter, because it is a direct method and requires less power the Model 405 nm is the preferred method for NO₂ while providing an accurate measurement of NO as well.

The Model 405 nm NO_x Monitor is approved as Federal Equivalent Method (FEM) [EQNA-0217-243](#) for NO₂ in the range of 0-500 ppb NO₂ for the operating temperature range of 20-30°C. SD card data logging is now a standard feature.

Theory of Operation

The following figure is a simplified schematic diagram of the Model 405 nm NO_x Monitor. Sample air is continuously drawn through the instrument by an air pump at a flow rate of ~2 L/min. The Scrubber Valve alternately bypasses and sends the sample air through a NO₂ scrubber to remove all NO₂ in the sample, thus allowing the measurement of a light intensity in the absence (I₀) of NO₂ and presence (I) of NO₂. The Beer-Lambert Law is then used to calculate the concentration of NO₂ from I and I₀.

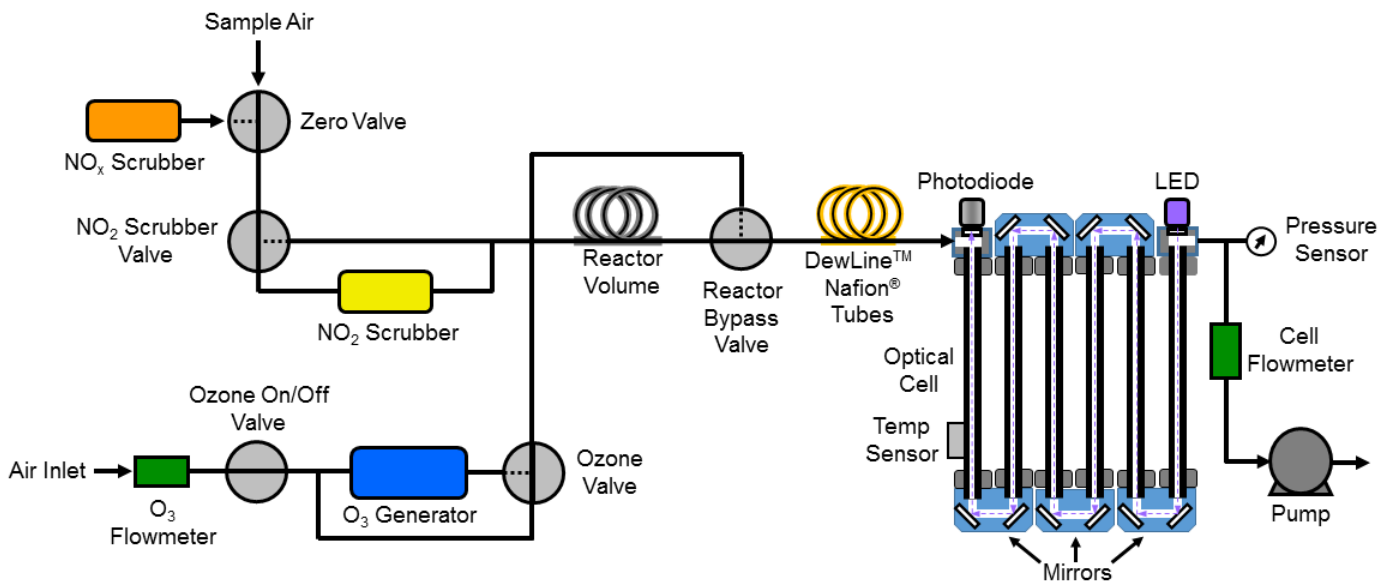

Fig. 1. Simplified schematic diagram of the Model 405 nm NO₂/NO/NO_x Monitor.

Nitric oxide is measured by bypassing the NO₂ Scrubber and measuring the light intensity while adding (I) or not adding (I₀) ozone to convert NO to NO₂ according to the reaction:



As in our ozone monitors and our Model 410 NO Monitor, a Nafion tube (the DewLine™) is used to equilibrate humidity during I and I₀ measurements, so that any water vapor interference due to refractive effects is eliminated.

NO_x is obtained by adding the measurements of NO₂ and NO. The instrument may be operated in continuous NO₂, or NO mode, or in a mode where NO₂ and NO are alternately measured, once every 20 seconds.

Features

- Direct measurement of NO₂ (absorbance at 405 nm) gives extreme selectivity for NO₂
- Measurement of NO₂ over the range 0-10 ppm, NO over the range 0-2 ppm, and NO_x
- FEM for NO₂ over the range 0-500 ppb and 20-30°C operating temperature range
- Three measurement modes: NO₂ only; NO only; NO, NO₂, and NO_x
- Power consumption: ~16 watts after warmup
- Long-life pump (~15,000 hours)
- Internal data logger (EEPROM) logs 8,192 lines of data
- Flash memory (SD card) for virtually unlimited, portable data logging
- Both serial and user-scalable analog voltage outputs for NO and NO₂
- Convenient user interface to microprocessor, including calibration parameters (gain and zero)
- Selectable measurement time of 5 s or data averaging times of 1 min, 5 min and 1 hr
- Selectable units for NO₂, NO, NO_x
- DewLine™ for elimination of any water vapor interference, a unique feature of 2B Tech instruments

Options

- Bluetooth for wireless data transmission
- Serial-to-USB converter

Specifications

Principle of Measurement	Direct absorbance of NO ₂ at 405 nm
Federal Equivalent Method (FEM)	Yes, EQNA-0217-243 for NO ₂ (0-500 ppb, 20-30°C)
Measurement Modes	NO ₂ only; NO only; NO, NO ₂ and NO _x
Linear Dynamic Range	0-10,000 ppb (0-10 ppm) for NO ₂ ; 0-2,000 ppb (0-2 ppm) for NO. FEM-approved for 0-500 ppb NO ₂ from 20-30°C.
Resolution	0.1 ppb
Precision (1σ; rms noise)	< 0.5 ppb or 0.5% of reading (with adaptive filter ¹)
Accuracy	Greater of 2 ppb or 2% of reading
Limit of Detection (2σ)	< 1 ppb (with adaptive filter ¹)
Flow Rate (nominal)	1.8 Liter/min
Flow Rate Requirement	1.4 Liter/min
Response Time, 100% of Step Change	10 s for 5-s averaging 20 s with adaptive filter ¹
Measurement Frequency	0.2 Hz (once every 5 s)
Averaging Times	5 s, 1 min, 5 min, 1 hr

Internal Data Logger Capacity	8,192 lines; increased capacity with optional internal micro-SD Drive
SD Data Logger Capacity	Minimum 2 GB (>2-year capacity for 5-s measurement mode)
Concentration Units	ppb, pphm, ppm
Pressure Units	mbar
Temperature Units	°C
T and P Corrected	Yes
Operating Temperature Range	10 to 50°C (FEM approval for NO ₂ for 20-30°C)
Operating Altitude	~0-30 km (~30-1000 mbar)
Power Requirement	11-14 V dc or 120/240 V ac, 1.3 A at 12 V, 16 watt Max: 2.5 A at 12 V, 30 watt (warmup)
Size	Rackmount: 17" w x 14.5" d x 5.5" h (43 x 37 x 14 cm)
Weight	18.6 lb. (8.4 kg)
Data Outputs	RS232; 0-2.5 V Analog Outputs for NO and for NO ₂
Data Transfer Baud Rates	2400
Output Ranges	User-defined scaling factor in menu
DewLine™	Yes
Long Life Pump	Yes, 15,000 hr, 1.7 yr of continuous operation
Flow Meter	Yes
Options	Bluetooth for wireless data transmission; USB output (in place of RS232)

¹ An adaptive filter may be selected from the menu, making signal averaging similar to competing NO_x monitors. Specifications above are for default parameters: Change Difference = 40 ppb, Change Percent = 10%, Short Filter = 4 pts (20 s), Long Filter = 36 pts (3 min). Adaptive filter parameters may be adjusted by the user.

System Includes

- Model 405nm NO₂/NO/NO_x Monitor
- 5A Power Adapter (5 amp, 100-240 VAC to 12 VDC) with select power cord
- Serial Port Cable (9PinF-9PinF)
- External (Zero) Nafion Assembly
- SD Card and SD Card Reader
- Operation Manual on USB Stick
- Calibration Data and NIST-Traceable Calibration Certificate
- Instrument Birth Certificate
- One-Year Warranty